

Description	Diaphragm miniature pressure regulator made of plastic and of small and lightweight design. Regulator R039 has increased accuracy due to a rolling diaphragm and a piston compensated to inlet pressure.
Media	compressed air, non-corrosive gases or liquids
Supply pressure	max. 16 bar
Air consumption	without constant bleed, except for R039-F with max. 3 l/min air consumption
Adjustment	by plastic knob with snap-lock
Relieving function	relieving for compressed air, red adjusting knob non-relieving for liquids, black adjusting knob
Gauge port	G $\frac{1}{8}$ on both sides of the body, screw plugs supplied
Mounting position	any
Temperature range	0 °C to 50 °C / 32 °F to 122 °F for NBR/Buna-N 0 °C to 70 °C / 32 °F to 158 °F for EPDM
Material	Body: POM with brass thread insert Elastomer: NBR/Buna-N, optionally EPDM Inner valve: brass, optionally stainless steel at EPDM version

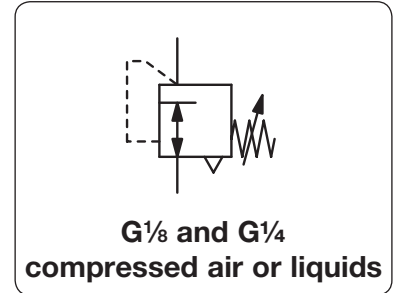

Dimensions			Flow rate		Connection	Pressure	Order no.	Order no.
A	B	C	water	air	thread	range	for water	compressed air
mm	mm	mm	l/min*1	l/min*1	G	bar	non-relieving	relieving

Miniature pressure regulator							supply pressure max. 16 bar		R038
40	76	11	5	350	G $\frac{1}{8}$	0.2 ... 2	R038-01AK	R038-01A	
						0.2 ... 4	R038-01BK	R038-01B	
						0.3 ... 8	R038-01CK	R038-01C	
						0.3 ... 12	R038-01DK	R038-01D	
40	76	11	5	380	G $\frac{1}{4}$	0.2 ... 2	R038-02AK	R038-02A	
						0.2 ... 4	R038-02BK	R038-02B	
						0.3 ... 8	R038-02CK	R038-02C	
						0.3 ... 12	R038-02DK	R038-02D	



R038-02C R039-01CK

Regulator w. increased accuracy							supply pressure max. 16 bar, w. rolling diaphragm, inlet pressure-compensated		R039
40	76	11	5	350	G $\frac{1}{8}$	0.2 ... 2	R039-01AK	R039-01A	
						0.2 ... 4	R039-01BK	R039-01B	
						0.3 ... 8	R039-01CK	R039-01C	
						0.3 ... 12	R039-01DK	R039-01D	
40	76	11	5	380	G $\frac{1}{4}$	0.2 ... 2	R039-02AK	R039-02A	
						0.2 ... 4	R039-02BK	R039-02B	
						0.3 ... 8	R039-02CK	R039-02C	
						0.3 ... 12	R039-02DK	R039-02D	



R038-01BKME free of non-ferrous metal, SST and EPDM

Special options, add the appropriate letter			
precision regulator	with constant bleed	R039 only	R039-0 . . F
plastic housing	EPDM elastomer, SST inner valve	R038-01 . K only	R038-01 . KME
adjustment lock	non-adjustable knob		R03 . -0 . . T
free of grease and oil	specially cleaned, suitable for oxygen	R038 only	R038-0 . . L
without gauge port			R03 . -0 . . X02
for oxygen	specially cleaned, with oxygen grease	not for R039-0..F	R039-0 . . 15

Accessories, enclosed

pressure gauge	Ø 40 mm, 0...*2 bar, G $\frac{1}{8}$	MA4001- . . *2
mounting bracket	made of steel	BW30-02
mounting nut	made of plastic	M30x1,5K
	made of aluminium	M30x1,5A

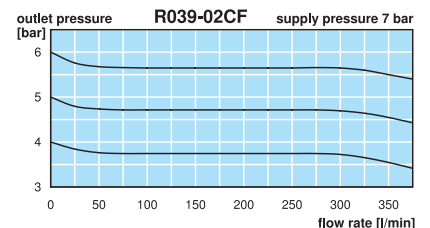
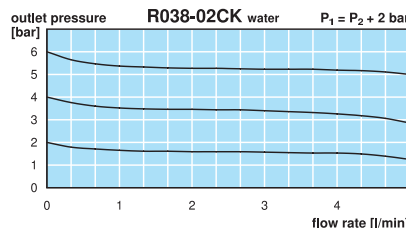
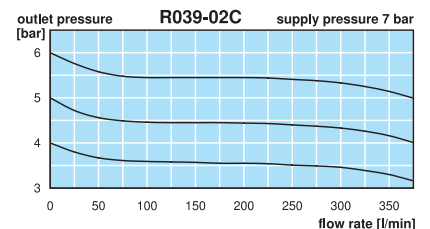
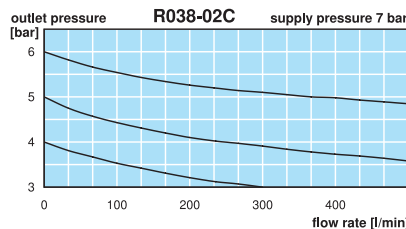
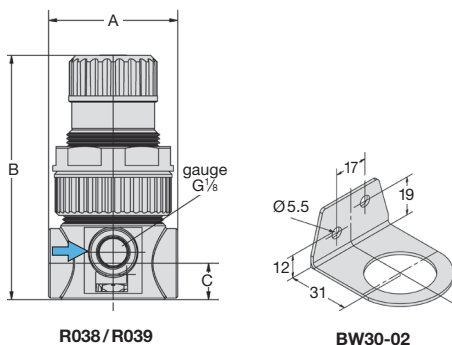

*1 at 7 bar supply pressure, 6 bar outlet pressure and 1 bar pressure drop, for water: supply pressure 2 bar above outlet pressure.
*2 02 = 0...2.5 bar, 04 = 0...4 bar, 10 = 0...10 bar, 16 = 0...16 bar